

RESIDENTIAL UNCOVERED DECKS & PORCHES

The purpose of this guide is to assist you in the permit process for your project. This handout is intended as a basic plan submittal under the 2015 International Residential Code. It is not intended to cover all circumstances. Depending on the scope and complexity of your project, additional and/or more detailed plans may be required. If you are unsure whether your project will require a permit, please feel free to contact the Building Services Division at (303) 325-8000.

This permitting process is not intended to take the place of any Homeowner Association (HOA) or Civic Association requirements; therefore, it is important for you to check with your HOA or CA for any additional requirements they may have.

HOW TO USE THIS GUIDE

SUBMIT A COMPLETED PERMIT APPLICATION

Applications may be submitted on the City of Centennial website by clicking [HERE](#). It is important that the permit/application is filled out completely to the best of your knowledge and that you provide any additional pertinent information (i.e., owner and contractor contact information). Fill in the blanks on page two (2) and indicate which construction materials will be used. It is important to print legibly to help staff review the submitted information. In most cases, the information provided within this worksheet will satisfy the City's requirement for a complete submittal.

PROVIDE SITE/PLOT PLANS

1. Show the dimensions of your project and its relationship to existing setbacks easements, structures on the property and the distance to property lines (an example is shown below). Identification of the location of existing easements are the responsibility of the property owner. Structures shall not be located on easements. To download a plot plan of your residence, click [HERE](#) to go to the Arapahoe County Assessor's website.

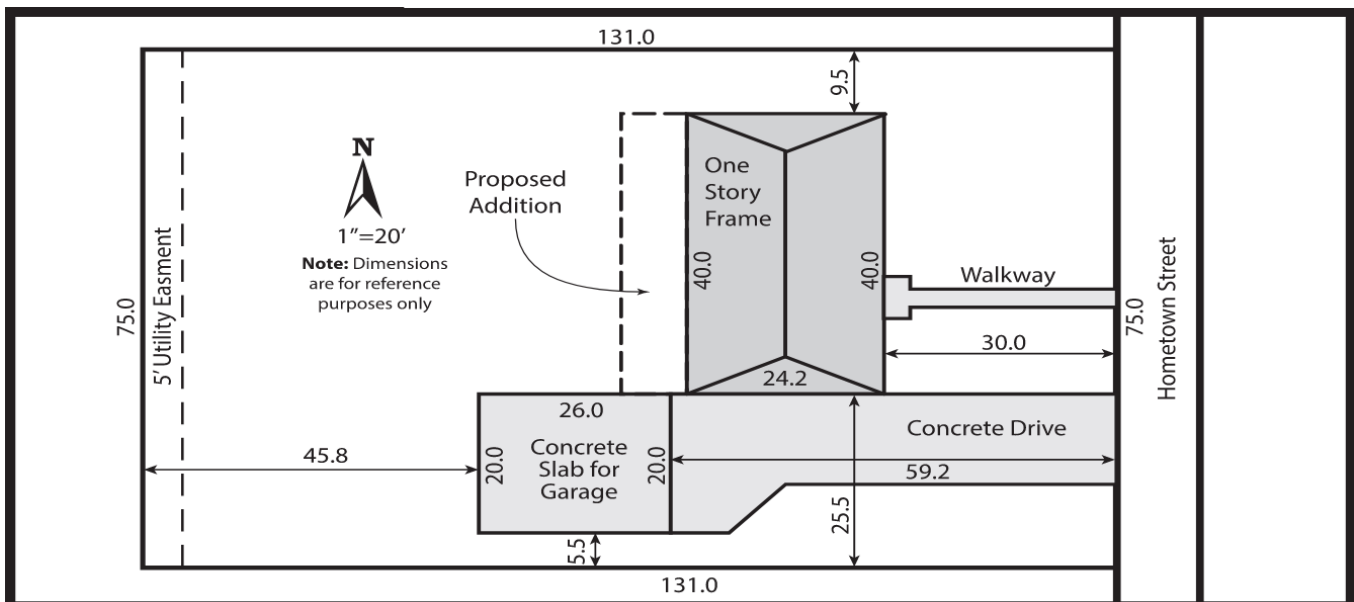



RESIDENTIAL UNCOVERED DECKS & PORCHES

PROVIDE PLOT PLANS HERE:



Centennial C O L O R A D O

RESIDENTIAL UNCOVERED DECKS & PORCHES

DIRECTIONS

1. Fill in the blanks on this page with dimensions and materials which will be used to build the structure. Please print legibly.
2. Indicate in the check boxes on this page which detail from page three (3) will be used.

JOB SITE ADDRESS _____

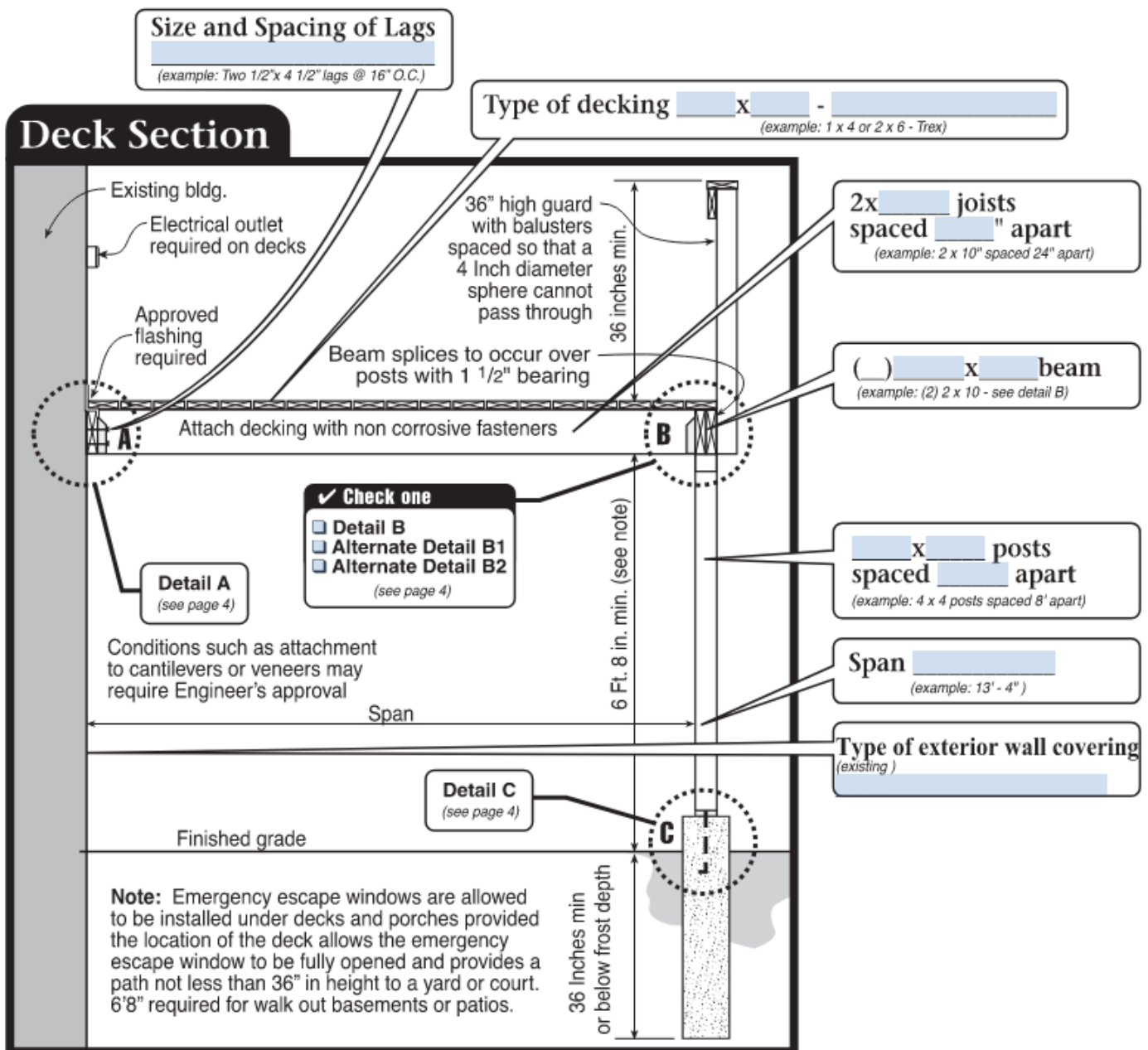

NOTE: If deck or porch will be attached to a masonry (brick) wall, please provide detail on fasteners that will be used.

RESIDENTIAL UNCOVERED DECKS & PORCHES

CONSTRUCTION DETAILS (CONTINUED)

Detail A

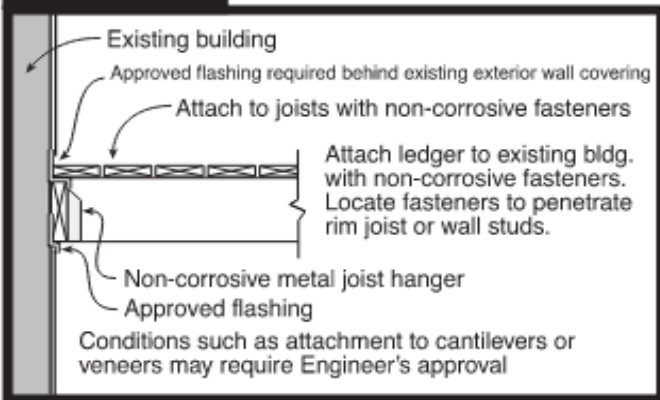

Detail B

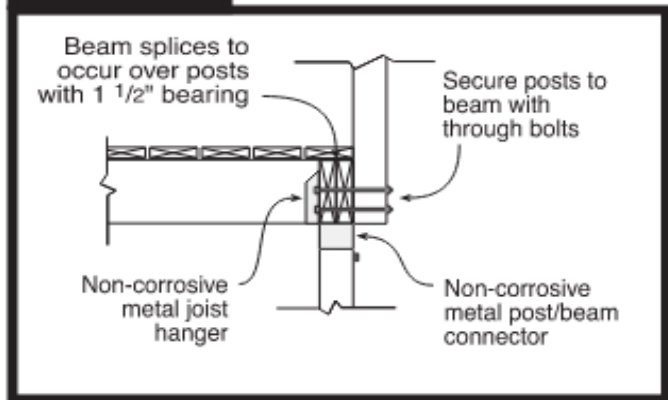

Alternate Detail B1

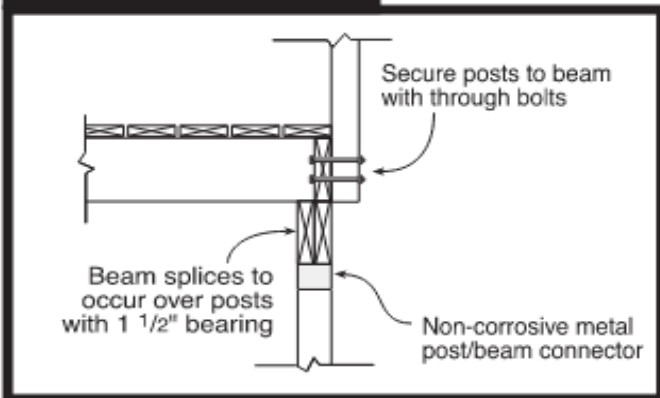

Alternate Detail B2

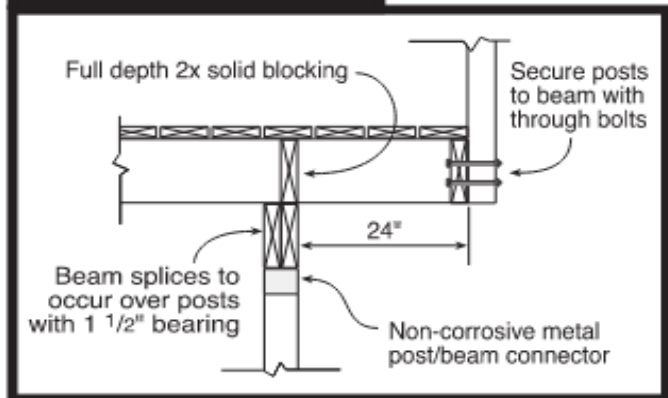

Detail C

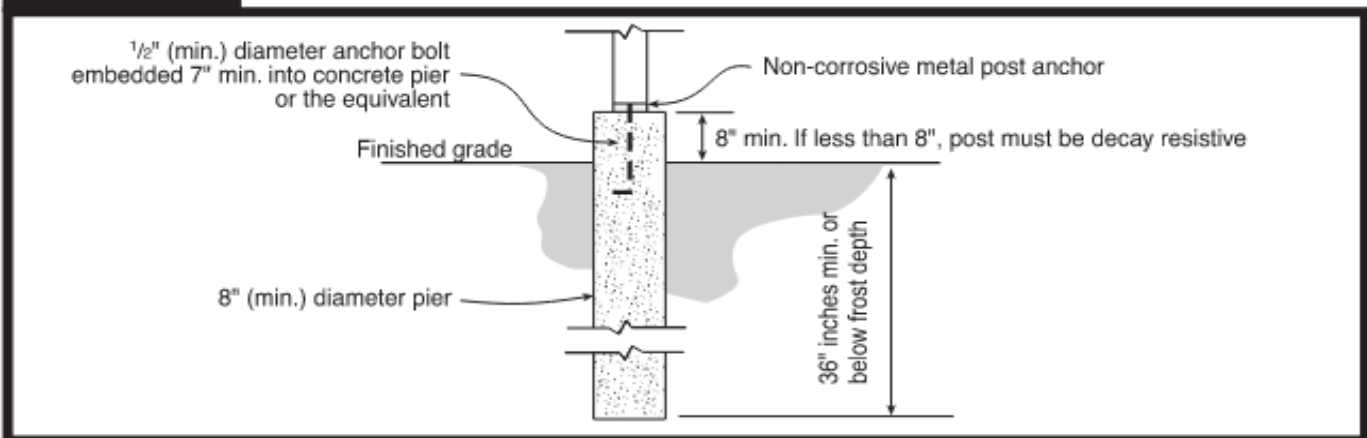



Centennial

C O L O R A D O

RESIDENTIAL UNCOVERED DECKS & PORCHES

Stair & Handrail Specifications

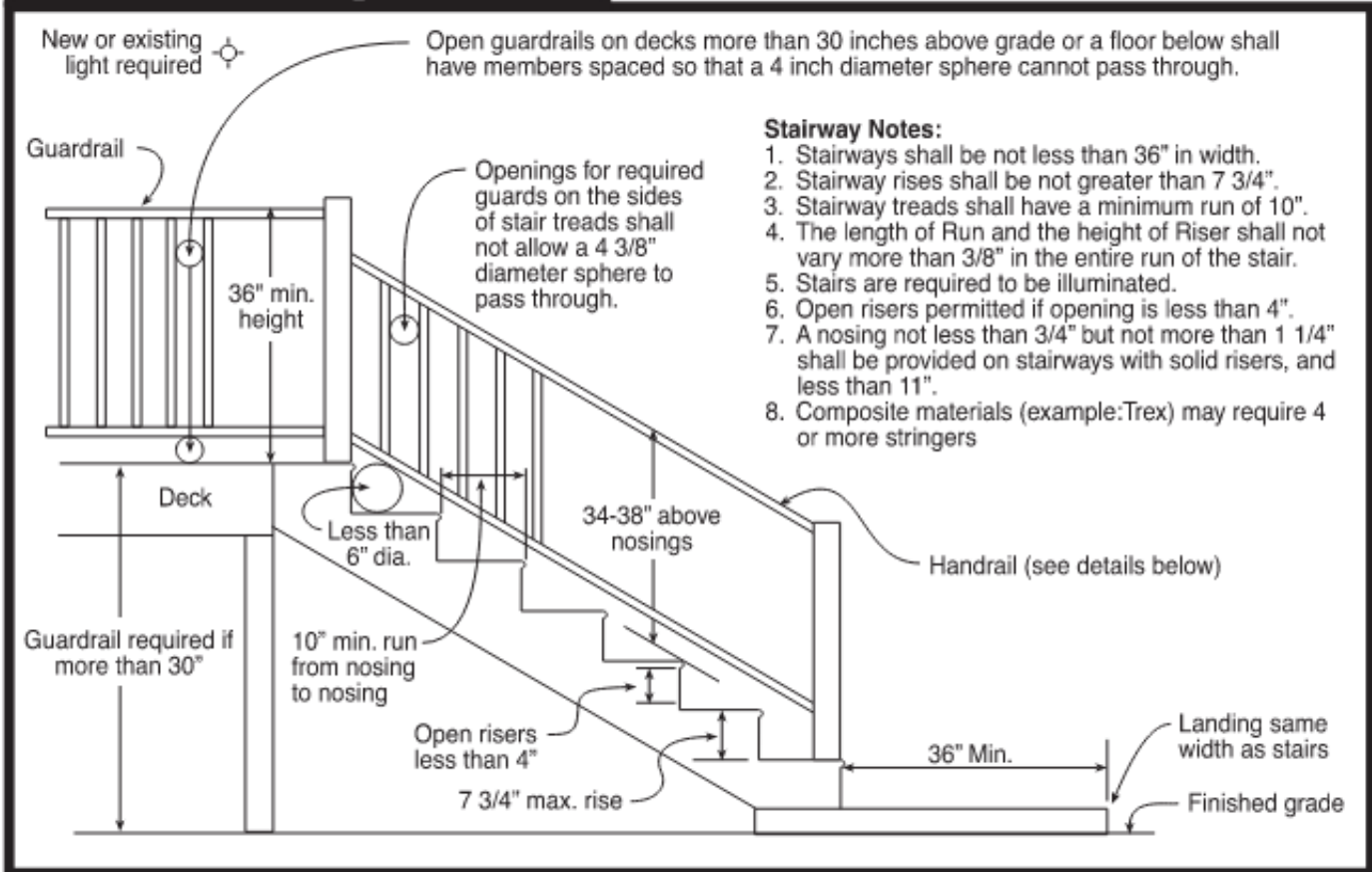

Handrail Notes:

1. Handrails shall be continuous on at least one side of stairs with 4 or more risers.
2. Top of the handrails shall be placed not less than 34 inches nor more than 38 inches above stair nosings.
3. The handgrip portion of handrails shall be not less than 1-1/4 inches nor more than 2 1/4 inches in cross section for non circular handrails.
4. Handrails shall be placed not less than 1-1/2 inches from any wall or other surface.
5. Handrails to be returned to wall, post or safety terminal (per 311.7.8.2 IRC)

Acceptable Handrail Details

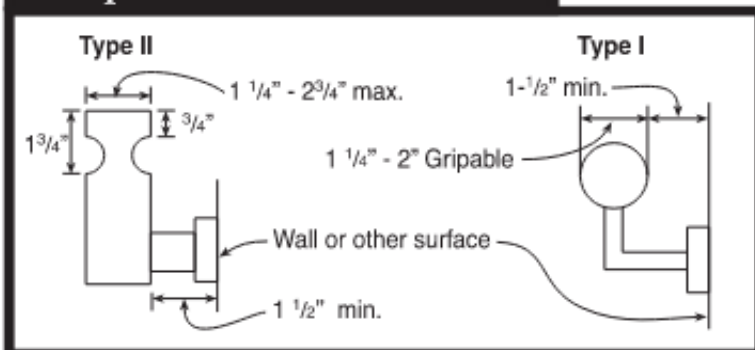

Unacceptable Handrails

